

**ENGINEERING SERVICES]  
EXAMINATION-2014**

Serial No.

38992

A-DMHH-N-FFB

**ELECTRICAL ENGINEERING**

**Paper—II**

**(Conventional)**

*Time Allowed : Three Hours*

*Maximum Marks : 200*

**INSTRUCTIONS**

*Please read each of the following instructions carefully before attempting questions :*

*Candidates should attempt FIVE questions in all.*

*Question No. 1 is compulsory.*

*Out of the remaining SIX questions attempt any FOUR questions.*

*All questions carry equal marks. The number of marks carried by a part/question is indicated against it.*

*Answers must be written in ENGLISH only.*

*Unless other-wise mentioned, symbols and notations have their usual standard meanings.*

*Assume suitable data, if necessary, and indicate the same clearly.*

*Neat sketches may be drawn, wherever required.*

*All parts and sub-parts of a question are to be attempted together in the answer book.*

*Attempts of questions shall be counted in chronological order.*

*Unless struck off, attempt of a question shall be counted even if attempted partly.*

*Any page or portion of the page left blank in the answer book must be clearly struck off.*

1. (a) What are the conditions under which a transformer works at maximum efficiency ? The Maximum efficiency of a 50 KVA transformer is 97.4% and occurs at 90% of full load at UPF. Calculate efficiency at (i) full load, 0.8 pf and (ii)  $\frac{1}{2}$  full load, 0.9 pf.
- (b) A 3-phase, 4-pole slip ring induction motor is connected to 3-phase, 50 Hz supply from the rotor side through slip rings and the stator terminals are shorted. The machine is found to be running at 1440 rpm. Determine :
  - (i) The frequency of stator current.
  - (ii) The speed of rotor magnetic field w.r.t. rotor and its direction w.r.t. direction of rotation of rotor.
  - (iii) The speed of stator magnetic field w.r.t. stator and its direction w.r.t. direction of rotation of rotor.
  - (iv) The speed of stator magnetic field w.r.t. rotor magnetic field.
- (c) Explain with phasor diagram as to why in an alternator under short circuit conditions core losses reduce very much.
- (d) A cylindrical rotor synchronous motor having negligible armature, resistance is connected to an infinite bus and is operating at no-load at normal excitation. What will happen if the excitation of the motor is (i) increased and (ii) decreased ? Explain with the help of phasor diagram.

- (e) The poles of the dc machine are laminated even though the field winding current is dc. Explain why ?
- (f) Assuming forward voltage drop across diodes to be 0.7 V, draw the transfer characteristic of the clipper circuit shown in figure.

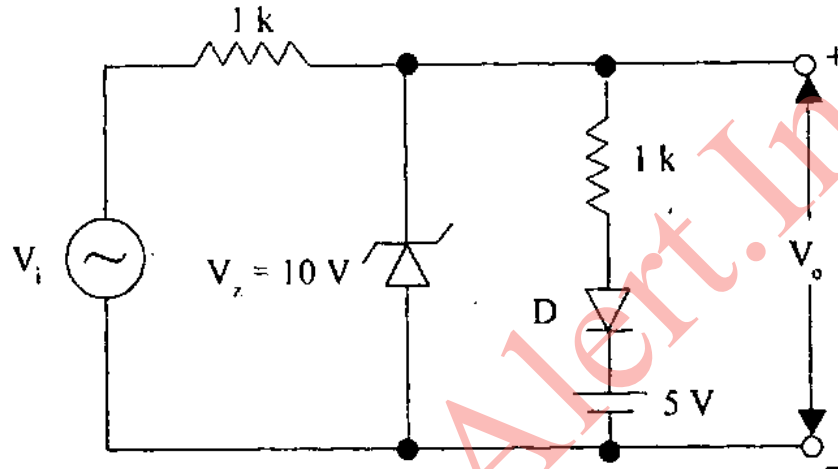

- (g) A voltage  $v_i = 1 + 2 \sin \omega t$  is applied to the circuit shown in figure. Draw the output voltage and capacitor voltage waveforms. Find the average output voltage. Assume  $\omega = 1\text{ rad/sec}$ .

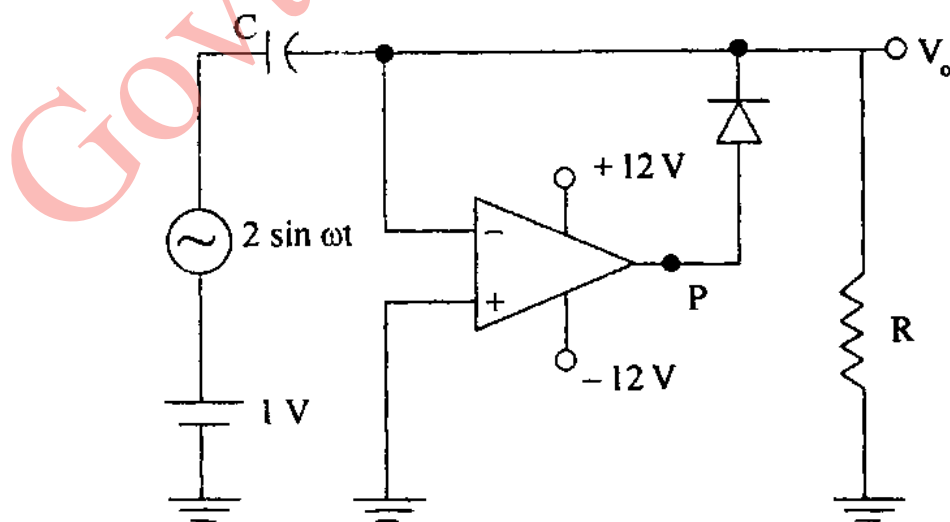

(3)

(Contd.)

- (h) Prove that two open collector TTL inverters when connected together produce the NOR gate.
- (i) “With highly inductive load a fully controlled converter works as an inverter whenever the delay angle is more than  $90^\circ$ ”. Is it true or false ? Explain with the help of waveforms.
- (j) A thyristor connected in series with inductive load (resistance = 0) is triggered at an angle  $\alpha$  in each positive half cycle. Draw the load voltage and load current. Derive the expression for load current. Comment on power flow.  $4 \times 10 = 40$
2. (a) A 150 kVA, 2400/240 V transformer has the following parameters referred to the primary side :  $R_1 = 0.5 \Omega$  and  $X_1 = 1.5 \Omega$ . The shunt magnetizing impedance is very large and can be neglected. At full load, the transformer delivers rated kVA at 0.85 lagging power factor and the secondary voltage is 240 V. Calculate :
- (i) The voltage regulation
- (ii) The efficiency assuming core losses to be 600 W. 10

- (b) Figure shows a small industrial distribution system. The power system supplies power at constant voltage of 480 V, and the impedance of the distribution lines is negligible. Load 1 is a  $\Delta$ -connected load with a phase impedance of  $10 \angle 30^\circ \Omega$ , and load 2 is a Y-connected load with a phase impedance of  $5 \angle -36.87^\circ \Omega$ .

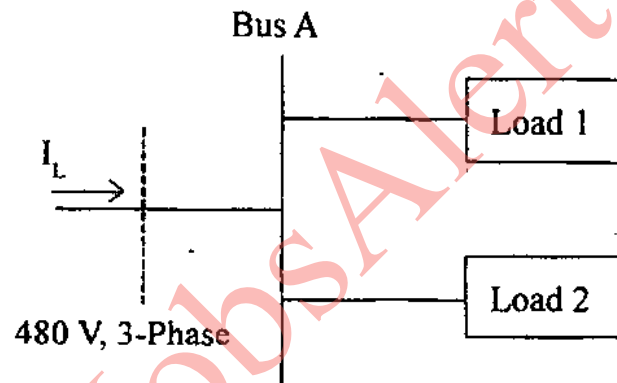

- (i) Find the overall power factor of the distribution system.
- (ii) Find the total current supplied to the distribution system. 15
- (c) A single-phase full bridge bipolar PWM inverter employs selective harmonic elimination method. The output voltage waveform of the inverter is

shown in figure. Obtain an expression for the amplitude of the  $n$ th harmonic component. How would you obtain the values of  $\alpha_1$ ,  $\alpha_2$  and  $\alpha_3$  that will permit the 3<sup>rd</sup> and 5<sup>th</sup> harmonic components to be eliminated keeping the fundamental at 0.5 pu. 10

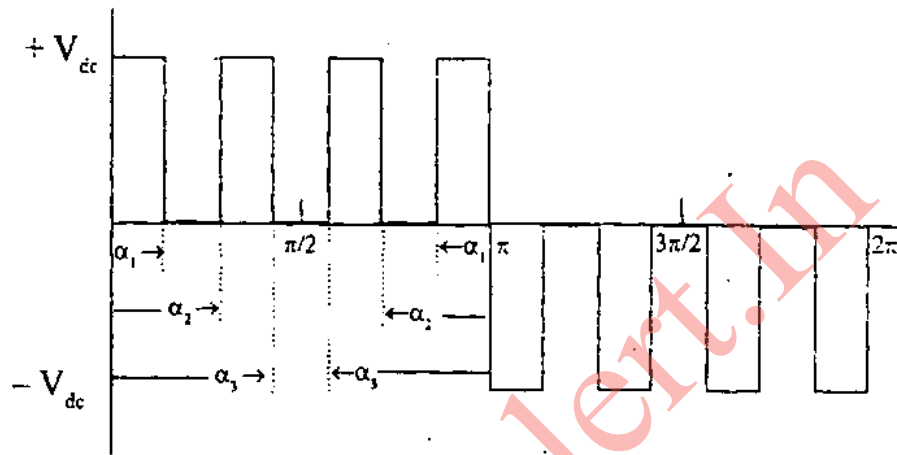

(d) Explain and differentiate Pulse Code Modulation (PCM) and Pulse Position Modulation (PPM). 5

3. (a) A 75-MVA, 13.8 kV, three-phase, eight-pole, 60 Hz salient pole synchronous machine has the following d-axis and q-axis reactances :  $X_d = 1.0$  p.u. and  $X_q = 0.6$  p.u. The synchronous generator is delivering rated MVA at rated voltage and 0.866 power factor lagging. Choose a power base of 75 MVA and voltage base of 13.8 kV.

- (i) Draw the phasor diagram of the machine.
- (ii) Compute the excitation voltage  $E_f$
- (iii) If the machine is connected to 3-phase system having 1.0 p.u. voltage, find the maximum power that generator can deliver. 15

(6)

(Contd.)

- (b) The single-phase ac voltage regulator has 120 V rms, 50 Hz source. The load resistance is 15 ohm. Determine the
- (i) delay angle required to deliver 500 W to the load
  - (ii) rms source current
  - (iii) input power factor
  - (iv) THD of the source current. 10
- (c) Discuss the operation of the relaxation oscillator circuit shown in figure with relevant waveforms. Derive expressions for the
- (i) UTP ( $V_H$ ) and (LTP) ( $V_L$ )
  - (ii) Frequency and duty cycle in terms of UTP and LTP. 15

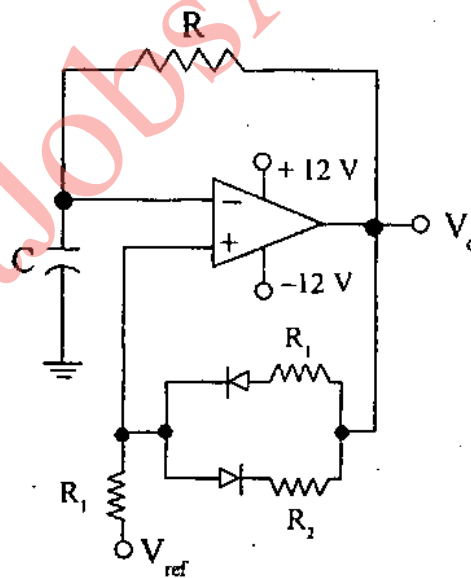

4. (a) A line commutated inverter transfers energy into a 440 V, 50 Hz three-phase supply from a battery of 500 V. The battery is linked to the converter through a large filter choke of resistance 12.4  $\Omega$ .

It is desired to transfer 5 kW power into the system.

- (i) Calculate the firing angle at which inverter is to be operated. Also, determine (a) Input power factor, (b) RMS value of fundamental ac current, (c) Efficiency of energy transfer.
- (ii) What is the maximum usable value of the SCR firing angle ?
- (iii) Calculate the SCR voltage and rms current rating. 15

(b) A 60-Hz, 3 phase transmission line is 200 km long. It has a total series impedance of  $35 + j 140 \Omega$  and a shunt admittance of  $930 \times 10^{-6} \angle 90^\circ \text{ S}$ . It delivers 40 MW at 220 kV and 0.9 power factor lagging.

- (i) Determine the voltage, current, and power factor at the sending end of the line.
- (ii) Find the voltage regulation and efficiency of the line. 15

(c) The block diagram of  $256 \times 4$  RAM chip is shown in figure (a). The chip is enabled only when  $\overline{\text{CS1}}$  and CS2 are active. Realize a  $2\text{K} \times 8$  RAM chip as shown in figure (b) using this chip as a building block. 10

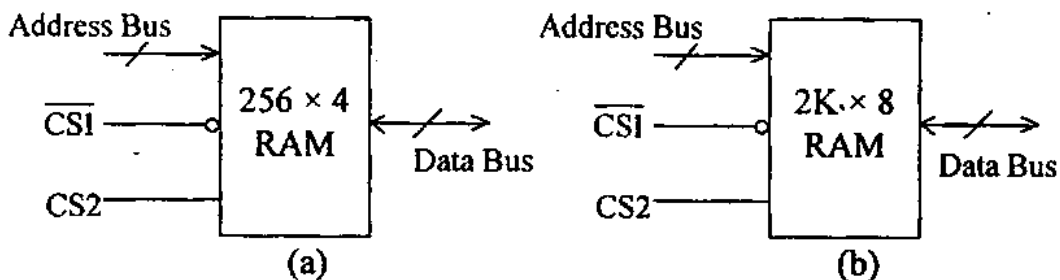



5. (a) Show how a string of insulators be protected against damage when a flash over occurs.

Each line of a 3-phase system is suspended by a string of three similar insulators. If the voltage across the line unit is 10 kV, determine the line voltage of the system. Assume that the shunt capacitance between each insulator and the earthed metalwork of the tower is one-tenth of the capacitance of the insulation itself. 10

- (b) Design a common emitter amplifier using the circuit shown in figure to obtain the maximum symmetrical output voltage swing. The design must be dc bias stable. (Use  $V_{BE} = -0.6 \text{ V}$ , and  $\beta = 200$ ). Determine

- (i)  $I_{CQ}$  and  $V_{CEQ}$
- (ii)  $R_1$  and  $R_2$
- (iii) Maximum symmetrical output voltage swing
- (iv) Power rating of the transistor
- (v) Amplifier ac power output. 15

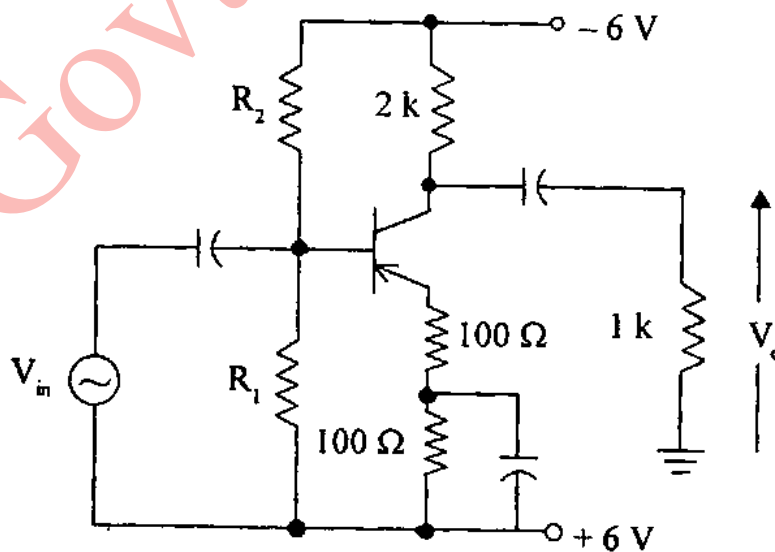

(9)

(Contd.)

- (c) A 208 V, 45 kVA, 0.8 p.f. leading  $\Delta$  connected 50 Hz synchronous machine has a synchronous reactance of  $2.5 \Omega$  and a negligible armature resistance. Its friction and windage losses are 1.5 kW, and its core losses are 1.0 kW. Initially, the shaft is supplying a 15 hp load, and the motor's power factor is 0.80 leading.
- (i) Draw the phasor diagram of the motor and find the line current and line-line voltage.
- (ii) If the shaft load is increased to 30 hp, find the new values of line current and line-line voltage and draw the phasor diagram. 15
6. (a) A single-phase distributor has loop resistance of  $0.3 \Omega$  and a reactance of  $0.4 \Omega$ . The far end of the distributor has a load current of 80 A and power factor of 0.8 lagging at 220 V. The mid-point M of the distributor has a load current of 50 A at power factor of 0.707 lagging with reference to voltage M. Calculate the sending end voltage and power factor. 15
- (b) A single-phase 2-pulse mid-point converter triggered at a firing angle of  $120^\circ$ , operates in inverter mode. The load inductance is such that current is discontinuous in nature. Draw output voltage, source current and thyristor voltage waveforms. 10

- (c) Using T flip flop and logic gates, design a L-M edge triggered flip-flop having a truth table as given below : 10

| L | M | Q+        |
|---|---|-----------|
| 0 | 0 | 0         |
| 0 | 1 | $\bar{Q}$ |
| 1 | 0 | 1         |
| 1 | 1 | $\bar{Q}$ |

- (d) The no load losses of a 3-phase induction machine are nearly constant from standstill to rated speed. Explain why. 5
7. (a) A 20 MVA, 11 kV, star-connected generator has positive, negative and zero sequence reactances of 25%, 35% and 10% respectively. The neutral is earthed through reactance of 8%. When the generator is unloaded, a short circuit occurs between two lines. Calculate the fault currents in all the phases and voltages assuming that the fault point is grounded. 10
- (b) In a voltage commutated chopper DC voltage input  $V = 250$  V, constant load current  $I_o = 20$  A, chopper frequency = 250 Hz, commutating components  $L = 1.25$  mH and  $C = 8$   $\mu$ F. Calculate the exact minimum average output voltage and circuit turn-off time. 10

(11)

(Contd.)

- (c) A logic circuit implements the following Boolean function :

$$F(A, B, C, D) = \bar{A}.C + A.\bar{C}.\bar{D}$$

It is found that the circuit input combination  $A = C$  can never occur. Find a simpler expression for  $F$ . 10

- (d) A 500 MVA, 20 kV, 60 Hz, four-pole synchronous generator is connected to an infinite bus through a purely reactive network. The generator has an inertia constant  $H = 6.0$  MJ/MVA and is delivering power of 1.0 pu to the infinite bus at steady state. The maximum power that can be delivered is 2.5 per unit. A fault occurs that reduces the generator output to zero. Determine the
- angular acceleration
  - speed in rpm at the end of 15 cycles. 10