

DO NOT OPEN THIS TEST BOOKLET UNTIL YOU ARE TOLD TO DO SO

T.B.C. : SKP-D-ETE

Test Booklet Series

Serial No.

0059513

**TEST BOOKLET**  
**ELECTRICAL ENGINEERING**

**A**

Time Allowed : Three Hours

Maximum Marks : 300

**INSTRUCTIONS**

1. IMMEDIATELY AFTER THE COMMENCEMENT OF THE EXAMINATION, YOU SHOULD CHECK THAT THIS TEST BOOKLET **DOES NOT** HAVE ANY UNPRINTED OR TORN OR MISSING PAGES OR ITEMS, ETC. IF SO, GET IT REPLACED BY A COMPLETE TEST BOOKLET.
2. PLEASE NOTE THAT IT IS THE CANDIDATE'S RESPONSIBILITY TO ENCODE AND FILL IN THE ROLL NUMBER AND TEST BOOKLET SERIES CODE A, B, C OR D CAREFULLY AND WITHOUT ANY OMISSION OR DISCREPANCY AT THE APPROPRIATE PLACES IN THE **OMR ANSWER SHEET**. ANY OMISSION/DISCREPANCY WILL RENDER THE ANSWER SHEET LIABLE FOR REJECTION.
3. You have to enter your Roll Number on the Test Booklet in the Box provided alongside. **DO NOT** write *anything else* on the Test Booklet.
4. This Test Booklet contains 150 items (questions). Each item comprises four responses (answers). You will select the response which you want to mark on the Answer Sheet. In case, you feel that there is more than one correct response, mark the response which you consider the best. In any case, choose **ONLY ONE** response for each item.
5. You have to mark your responses **ONLY** on the separate Answer Sheet provided. See directions in the Answer Sheet.
6. All items carry equal marks.
7. Before you proceed to mark in the Answer Sheet the response to various items in the Test Booklet, you have to fill in some particulars in the Answer Sheet as per instructions sent to you with your Admission Certificate.
8. After you have completed filling in all your responses on the Answer Sheet and the examination has concluded, you should hand over to the Invigilator **only the Answer Sheet**. You are permitted to take away with you the Test Booklet.
9. Sheets for rough work are appended in the Test Booklet at the end.
10. **Penalty for wrong Answers :**  
THERE WILL BE PENALTY FOR WRONG ANSWERS MARKED BY A CANDIDATE.
  - (i) There are four alternatives for the answer to every question. For each question for which a wrong answer has been given by the candidate, **one-third (0.33)** of the marks assigned to that question will be deducted as penalty.
  - (ii) If a candidate gives more than one answer, it will be treated as **wrong answer** even if one of the given answers happens to be correct and there will be same penalty as above to that question.
  - (iii) If a question is left blank i.e., no answer is given by the candidate, there will be **no penalty** for that question.

DO NOT OPEN THIS TEST BOOKLET UNTIL YOU ARE TOLD TO DO SO

1. Eigen values of the Matrix

$$\begin{bmatrix} 3 & -1 & -1 \\ -1 & 3 & -1 \\ -1 & -1 & 3 \end{bmatrix} \text{ are}$$

- (a) 1, 1, 1
- (b) 1, 1, 2
- (c) 1, 4, 4
- (d) 1, 2, 4

2. The solution of the differential equation

$$\frac{d^2y}{dx^2} - \frac{dy}{dx} - 2y = 3e^{2x},$$

where,  $y(0) = 0$  and  $y'(0) = -2$  is

- (a)  $y = e^{-x} - e^{2x} + xe^{2x}$
- (b)  $y = e^x - e^{-2x} - xe^{2x}$
- (c)  $y = e^{-x} + e^{2x} + xe^{2x}$
- (d)  $y = e^x - e^{-2x} + xe^{2x}$

3. If  $Z = e^{ax+by} F(ax - by)$ ; the value of

$$b \cdot \frac{\partial Z}{\partial x} + a \cdot \frac{\partial Z}{\partial y} \text{ is}$$

- (a)  $2Z$
- (b)  $2a$
- (c)  $2b$
- (d)  $2abZ$

4. The general integral of the partial differential equation

$$y^2p - xyq = r(z - 2y) \text{ is}$$

- (a)  $\phi(x^2 + y^2, y^2 - yz) = 0$
- (b)  $\phi(x^2 - y^2, y^2 + yz) = 0$
- (c)  $\phi(xy, yz) = 0$
- (d)  $\phi(x + y, \ln x - z) = 0$

5. If  $\frac{d^2y}{dt^2} + y = 0$  under the conditions

$$y = 1, \frac{dy}{dt} = 0, \text{ when } t = 0,$$

then  $y$  is equal to

- (a)  $\sin t$
- (b)  $\cos t$
- (c)  $\tan t$
- (d)  $\cot t$

6. If the system

$$2x - y + 3z = 2$$

$$x + y + 2z = 2$$

$$5x - y + az = b$$

has infinitely many solutions, then the values of  $a$  and  $b$ , respectively, are

- (a)  $-8$  and  $6$
- (b)  $8$  and  $6$
- (c)  $-8$  and  $-6$
- (d)  $8$  and  $-6$

7. Evaluate  $\oint_c \frac{1}{(z-1)^3 \cdot (z-3)} dz$

where  $c$  is the rectangular region defined by  $x=0$ ,  $x=4$ ,  $y=-1$  and  $y=1$

- (a) 1
- (b) 0
- (c)  $\frac{\pi}{2}i$
- (d)  $\pi(3+2i)$

8. The Fourier Transform of  $e^{-\frac{x^2}{2}}$  is

- (a)  $\frac{1}{2} \cdot e^{-\frac{\omega^2}{2}}$
- (b)  $e^{-\frac{\omega^2}{2}}$
- (c)  $\frac{\pi}{2}$
- (d)  $\sqrt{\pi}$

9. In a sample of 100 students, the mean of the marks (only integers) obtained by them in a test is 14 with its standard deviation of 2.5 (marks obtained can be fitted with a normal distribution). The percentage of students scoring 16 marks is

- (a) 36
- (b) 23
- (c) 12
- (d) 10

(Area under standard normal curve between  $z=0$  and  $z=0.6$  is 0.2257; and between  $z=0$  and  $z=1.0$  is 0.3413)

10. Consider a random variable to which a Poisson distribution is best fitted. It happens that  $P_{(x=1)} = \frac{2}{3} P_{(x=2)}$  on this distribution plot. The variance of this distribution will be

- (a) 3
- (b) 2
- (c) 1
- (d)  $\frac{2}{3}$

11. In Face-Centered Cubic structure (FCC), what number of atoms is present in each unit cell?

- (a) 18
- (b) 16
- (c) 14
- (d) 12

12. If ( $n$ ) is lattice points per unit cell of the cubic system, ( $N$ ) and ( $M$ ) are the Avogadro's number and atomic weight, respectively, and ( $\rho$ ) is the density of the element, then the lattice constant ( $a$ ) is

- (a)  $\left(\frac{M\rho}{nN}\right)^{\frac{1}{3}}$
- (b)  $\left(\frac{NM}{n\rho}\right)^{\frac{1}{3}}$
- (c)  $\left(\frac{nM}{N\rho}\right)^{\frac{1}{3}}$
- (d)  $\left(\frac{N\rho}{nM}\right)^{\frac{1}{3}}$

13. The magnetic susceptibility of aluminium is  $2.1 \times 10^{-5}$ . The permeability and relative permeability are, respectively

- (a)  $12.6 \times 10^{-7}$  and 1.0021
- (b)  $1.26 \times 10^{-7}$  and 1.0021
- (c)  $12.6 \times 10^{-7}$  and 1.000021
- (d)  $1.26 \times 10^{-7}$  and 1.000021

14. An iron rod of  $10^{-3} \text{m}^3$  volume and relative permeability of 1150 is placed inside a long solenoid wound with 5 turns/cm. If a current of 0.5 A is allowed to pass through the solenoid, the magnetic moment of the rod is

- (a)  $2.87 \times 10^4 \text{ A.m}^2$
- (b)  $28.7 \times 10^3 \text{ A.m}^2$
- (c)  $2.87 \times 10^2 \text{ A.m}^2$
- (d)  $28.7 \times 10^2 \text{ A.m}^2$

15. When an alternating voltage of a given frequency is applied to a dielectric material, dissipation of energy occurs due to

1. Continual change in the orbital paths of the electrons in the atomic structure
2. A small conduction current through the dielectric
3. Eddy currents

Which of the above statements are correct ?

- (a) 1, 2 and 3
- (b) 1 and 2 only
- (c) 1 and 3 only
- (d) 2 and 3 only

16.

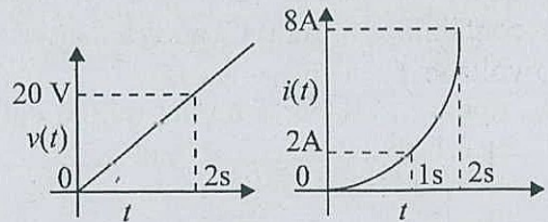

The voltage and current characteristic of an element is as shown in figure. The nature and value of the element are

- (a) Capacitor of  $3.3 \mu\text{F}$
- (b) Inductor of 2.5 H
- (c) Capacitor of  $6.7 \mu\text{F}$
- (d) Inductor of 5.0 H

17.

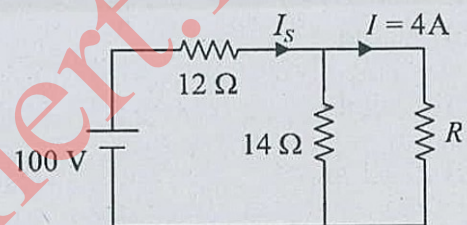

In the circuit shown, what value of  $R$  will result in  $I = 4 \text{ A}$  ?

- (a)  $9 \Omega$
- (b)  $7 \Omega$
- (c)  $5.5 \Omega$
- (d)  $3.5 \Omega$

18.

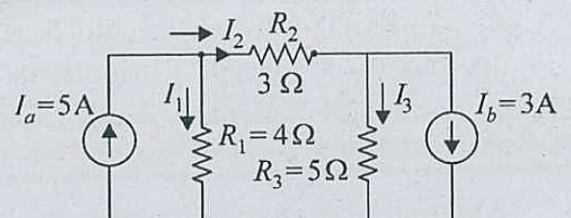

In the circuit as shown, the currents  $I_1$ ,  $I_2$  and  $I_3$  through three resistors are, respectively

- (a) 2.08 A, 2.92 A and  $-0.08 \text{ A}$
- (b) 3.08 A, 2.5 A and  $-0.06 \text{ A}$
- (c) 2.08 A, 2.5 A and  $-0.08 \text{ A}$
- (d) 3.08 A, 2.92 A and  $-0.06 \text{ A}$

19. The  $v-i$  relationship for a circuit containing  $R$  and  $C$  and a battery of voltage  $E$ , all in series is

1.  $\frac{1}{C} \int idt + iR = E$

2.  $\frac{1}{RC} i + \frac{di}{dt} = 0$

3.  $\frac{1}{C} i + R \int idt = E$

Which of the above relationships are correct ?

- (a) 1 and 2 only
- (b) 1 and 3 only
- (c) 2 and 3 only
- (d) 1, 2 and 3

20. The flux-density at a distance of 0.1 m from a long straight wire, carrying a current of 200 A is

- (a)  $5 \times 10^{-4}$  Wb/m<sup>2</sup>
- (b)  $4 \times 10^{-4}$  Wb/m<sup>2</sup>
- (c)  $3 \times 10^{-4}$  Wb/m<sup>2</sup>
- (d)  $2 \times 10^{-4}$  Wb/m<sup>2</sup>

21.

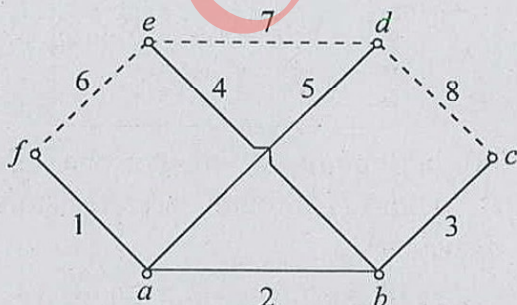

A network graph with its tree shown by firm lines is given in the figure. The fundamental cut-set for the tree-branch number 2 is

- (a) 1, 2, 3, 4 and 5
- (b) 1, 2 and 5
- (c) 2, 6, 7 and 8
- (d) 2, 3 and 4

22. A bipolar transistor has  $\alpha = 0.98$ ,  $I_{co} = 10 \mu A$ . If the base current is  $100 \mu A$ , then collector current would be

- (a) 2.91 mA
- (b) 3.49 mA
- (c) 4.91 mA
- (d) 5.49 mA

23. The reduced incidence matrix for a network is given as

$$A = \begin{matrix} & \begin{matrix} 1 & 2 & 3 & 4 & 5 & 6 \end{matrix} \\ \begin{matrix} a \\ b \\ c \end{matrix} & \begin{bmatrix} 1 & -1 & -1 & -1 & 0 & 0 \\ 0 & 1 & 0 & 0 & -1 & 1 \\ 0 & 0 & -1 & 0 & 1 & 0 \end{bmatrix} \end{matrix}$$

Which of the following sets constitute a tree ?

- (a) 2, 3 and 5
- (b) 1, 2 and 6
- (c) 1, 2 and 4
- (d) 1, 2 and 3

24.

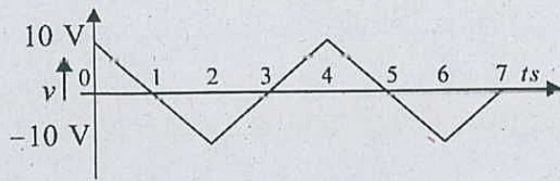

A triangular wave voltage, as shown in figure, is applied across the terminals of a 0.5 F pure capacitor at time  $t = 0$ .

The corresponding current-wave is

(a)

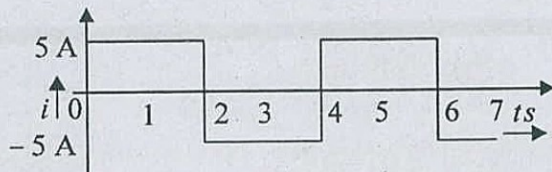

(b)

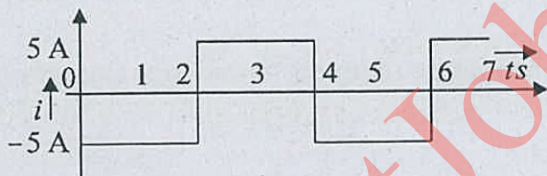

(c)

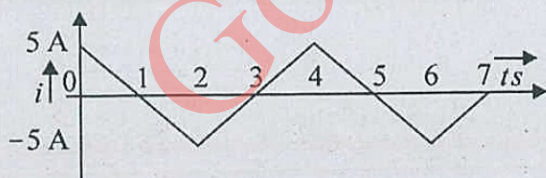

(d)

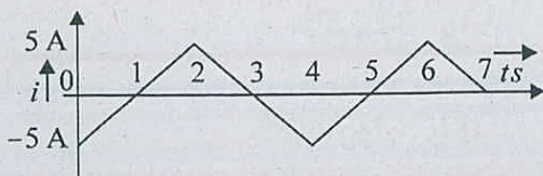

25. Consider the following statements for Norton's theorem :

1. Short the branch resistance through which current is to be calculated
2. Obtain the current through this short-circuited branch, using any of the network simplification techniques
3. Develop Norton's equivalent circuit by connecting current source  $I_N$  with the resistance  $R_N$  in series with it

Which of the above statements are correct ?

- (a) 1, 2 and 3
- (b) 1 and 3 only
- (c) 1 and 2 only
- (d) 2 and 3 only

26.

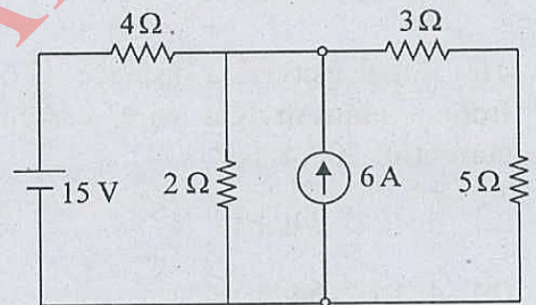

For the network shown in the figure, the current flowing through the  $5\Omega$  resistance will be

- (a)  $\frac{37}{25}$  A
- (b)  $\frac{40}{28}$  A
- (c)  $\frac{39}{28}$  A
- (d)  $\frac{41}{28}$  A

27.

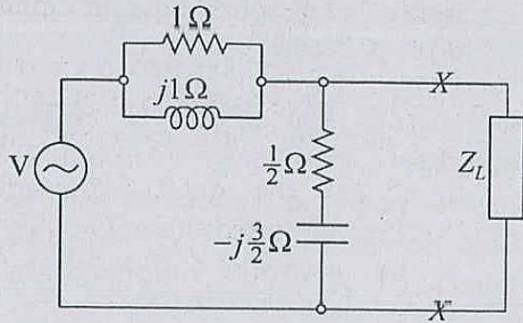

The circuit as shown in figure is connected to a load  $Z_L$  across  $X-X$ . For a maximum power transfer to the load,  $Z_L$  should be

- (a)  $\frac{3-j}{4} \Omega$
- (b)  $\frac{3+j}{4} \Omega$
- (c)  $\frac{3j}{4} \Omega$
- (d)  $\frac{-3-j}{4} \Omega$

28.

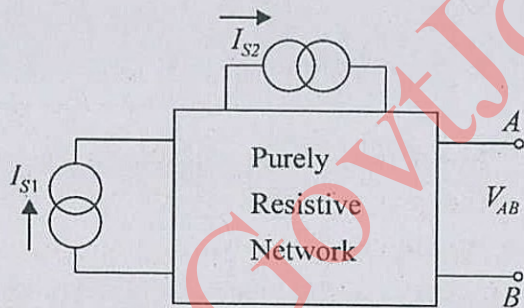

In the network as shown, with  $I_{S1} = 5A$ ,  $I_{S2} = 10A$ ,  $V_{AB} = 120V$ , and with  $I_{S1} = 10A$ ,  $I_{S2} = 5A$ ,  $V_{AB} = 15V$ . What is the value of  $k$  to describe  $I_{S1} = k I_{S2}$ , such that  $V_{AB} = 0$ ?

- (a) 2.5
- (b) 3.5
- (c) 5.5
- (d) 6.5

29.

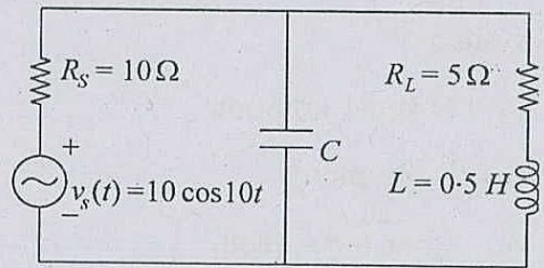

For the circuit as shown, what is the value of  $C$  that leads to maximum power transfer to the load, if the value of  $L$  is  $0.5 H$ ?

- (a)  $0.1 \mu F$
- (b)  $0.01 F$
- (c)  $0.001 F$
- (d)  $0.01 \mu F$

30.

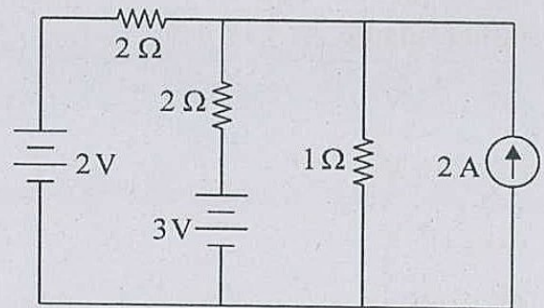

The current in the  $1\Omega$  resistor in the network as shown is

- (a) 2.00 A
- (b) 2.25 A
- (c) 2.50 A
- (d) 2.75 A

31. Which of the following is considered a time domain technique in control systems ?

- (a) Nyquist criterion
- (b) Bode plot
- (c) Root locus plot
- (d) Routh-Hurwitz criterion

32.

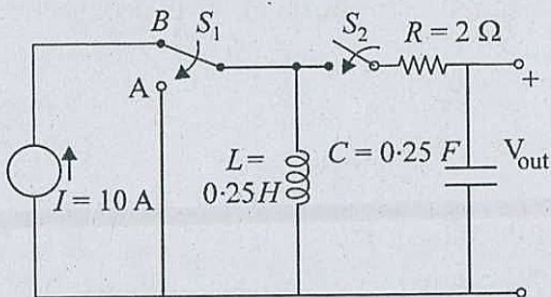

For the circuit as shown, consider that switch  $S_1$  has been in position  $B$  for a very long time and switch  $S_2$  has been open all the time. At time  $t=0$ , the switch  $S_1$  moves to position  $A$  and switch  $S_2$  closes instantaneously. What is the value of  $V_{out}$  at  $t=0^+$ , assuming initial charge on  $C=0$  ?

- (a) 2.5 V
- (b) 2.0 V
- (c) 1.5 V
- (d) 0 V

33. What is phasor sum of currents  $I_1 = 10(a - a^2)$  and  $I_2 = -j10$  for two complex operators which are individually defined by  $a^3 = 1$  and  $j^2 = -1$  ?

- (a)  $17.32 \angle 90^\circ$
- (b)  $7.32 \angle 90^\circ$
- (c)  $17.32 \angle 0^\circ$
- (d)  $7.32 \angle 0^\circ$

34. A series  $RLC$  circuit with  $R=2\Omega$ ,  $L=\frac{1}{2}H$ ,  $C=\frac{1}{4}F$  is excited by a 100 V dc source. The circuit is initially in quiescent state. The expression for the current response  $i(t)$  due to a dc source will be of the form ( $K, K_1, K_2$  are constants)

- (a)  $Ke^{-4t} \sin\left(4t + \frac{\pi}{3}\right)$
- (b)  $Ke^{-2t} \sin\sqrt{8}t$
- (c)  $(K_1 + K_2 t)e^{-2t}$
- (d)  $K_1e^{-2t} + K_2e^{-4t}$

35. The impulse response of an  $LTI$  system is given by  $5u(t)$ . If the input to the system is given by  $e^{-t}$  then the output of the system is

- (a)  $5(1 - e^{-t})u(t)$
- (b)  $(1 - 5e^{-t})u(t)$
- (c)  $5 - e^{-t}u(t)$
- (d)  $5u(t) - e^{-t}$

36. A series  $RLC$  circuit has a resistance of  $50\Omega$ , inductance of  $0.4H$  and a capacitor of  $10\mu F$ . The circuit is connected across a 100V supply. The resonance frequency and the current through the resistance are

- (a) 500 rad/s and 2 A
- (b) 1000 rad/s and 2 A
- (c) 500 rad/s and 0.5A
- (d) 1000 rad/s and 0.5A



37. A pulse of +10V in magnitude and 2s in duration is applied to the terminals of a lossless inductor of 1.0H. The current through the inductor would

- (a) be a pulse of +20A for the duration of 2s
- (b) be a pulse of -20A for the duration of 2s
- (c) increase linearly from zero to 20A in 2s, and in the positive direction, and, from thereon, it remains constant at +20A
- (d) increase linearly from zero to -20A in 2s, and in the negative direction, and, from thereon, it remains constant at -20A

38. Consider the following statements regarding power measurement of three-phase circuits by two-wattmeter method

1. Total power can be measured if the three-phase load is balanced and can be represented by an equivalent Y connection only
2. Total power can be measured for the three-phase load irrespective of, whether the load is balanced or not and connected in Y or Δ
3. Power factor can be calculated only if the three-phase load is balanced

Which of the above statements are correct ?

- (a) 1 and 2 only
- (b) 1 and 3 only
- (c) 2 and 3 only
- (d) 1, 2 and 3

39.

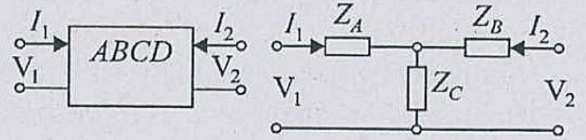

In terms of ABCD-parameters of a 2-port network, the parameters  $Z_A$ ,  $Z_B$  and  $Z_C$  of the equivalent-T-network are, respectively

- (a)  $\frac{A-1}{C}$ ,  $\frac{D-1}{C}$  and  $\frac{1}{C}$
- (b)  $\frac{A}{C}$ ,  $\frac{D-1}{C}$  and  $\frac{1}{C}$
- (c)  $\frac{A-1}{C}$ ,  $\frac{D}{C}$  and  $\frac{1}{C}$
- (d)  $\frac{A}{C}$ ,  $\frac{D}{C}$  and  $BC$

40.

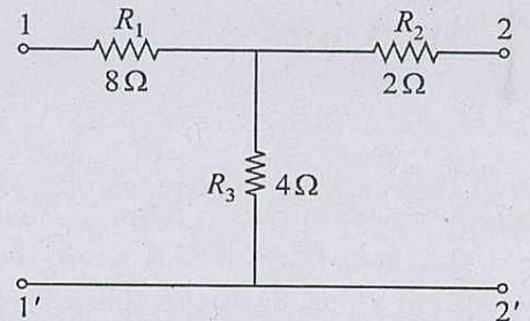

The Z parameters  $Z_{11}$ ,  $Z_{12}$ ,  $Z_{21}$  and  $Z_{22}$  for the circuit as shown in figure, respectively, are

- (a) 12Ω, 4Ω, 4Ω and 6Ω
- (b) 8Ω, 6Ω, 4Ω and 4Ω
- (c) 12Ω, 6Ω, 6Ω and 4Ω
- (d) 8Ω, 4Ω, 6Ω and 6Ω

41. A balanced 3-phase *RYB* sequence star-connected supply source with phase voltage 100V is connected to a delta-connected balanced load  $16 - j12\Omega$  per phase. The phase and line currents are, respectively

- (a)  $5\sqrt{3}\text{A}$  and 30A
- (b)  $10\sqrt{3}\text{A}$  and 30A
- (c)  $5\sqrt{3}\text{A}$  and 15A
- (d)  $10\sqrt{3}\text{A}$  and 15A

42. The maximum potential-gradient that can be imposed in air at atmospheric pressure without breakdown is 30 kV/cm. The corresponding energy density is nearly

- (a)  $30 \text{ J/m}^3$
- (b)  $35 \text{ J/m}^3$
- (c)  $40 \text{ J/m}^3$
- (d)  $45 \text{ J/m}^3$

43. A steady flow of 10A is maintained in a thin wire placed along the *X*-axis from (0, 0, 0) to (2, 0, 0) to find the value of the magnetic field intensity *H* at (0, 0, 5). When end effects are ignored, *H* is

- (a)  $-59.1 \hat{a}_y \text{ mA/m}$
- (b)  $59.1 \hat{a}_y \text{ mA/m}$
- (c)  $-118.2 \hat{a}_y \text{ mA/m}$
- (d)  $118.2 \hat{a}_y \text{ mA/m}$

44. A hollow metallic sphere of radius *R* is charged to a surface density of  $\sigma$ . The strength of the electric field inside the sphere at a radius  $r (< R)$  is

- (a)  $\frac{\sigma}{\pi r^2}$
- (b)  $\frac{\sigma}{2\pi r^2}$
- (c)  $\frac{\sigma}{4\pi r^2}$
- (d) zero

45.

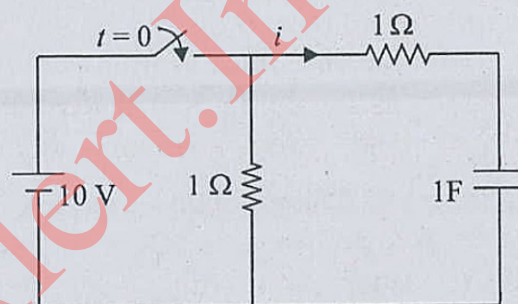

In the circuit as shown in figure, the switch is closed at  $t=0$ . The current through the capacitor will decrease exponentially with a time constant of magnitude

- (a) 0.5 s
- (b) 1 s
- (c) 2 s
- (d) 4 s

46. A parallel-plate capacitor with air between the plates has a capacitance of 10 pF. If the distance between the parallel plates is halved and the space between the plates is filled with a material of dielectric constant 5, the newly formed capacitor will have a capacitance of

- (a) 10 pF
- (b) 50 pF
- (c) 100 pF
- (d) 150 pF

47. Which of the following statements are correct regarding uniform plane waves ?

1. Uniform plane waves are transverse
2. The relation between  $E$  and  $H$  is  

$$\frac{E}{H} = \sqrt{\frac{\epsilon}{\mu}}$$
3.  $E \times H$  gives the direction of the wave travel
4. For a uniform plane wave travelling in  $x$  direction,  $E_x = 0$

- (a) 1, 2 and 3 only
- (b) 1, 3 and 4 only
- (c) 1, 2 and 4 only
- (d) 2, 3 and 4 only

48. An energy meter makes 100 revolutions of its disc per unit of energy. The number of revolutions made by the disc during one hour when connected across 210V source and drawing a current of 20A at 0.8 p.f. leading is

- (a) 336
- (b) 316
- (c) 286
- (d) 256

49. Consider the following statements regarding Computer Architecture :

1. The advantage with dedicated bus is decrease in size and cost

2. In synchronous timing, the occurrence of events on the bus is determined by the clock

3. Data bus width decides the number of bits transferred at one time

Which of the above statements are correct ?

- (a) 1 and 2 only
- (b) 1 and 3 only
- (c) 2 and 3 only
- (d) 1, 2 and 3

50. Consider the following statements :

1. Better memory utilization is possible with non-contiguous allocation using fixed size pages
2. Associative memory is used for providing fast access to data stored in cache memory.
3. Direct mapping of cache memory is hard to implement

Which of the above statements are correct ?

- (a) 1 and 2 only
- (b) 1 and 3 only
- (c) 2 and 3 only
- (d) 1, 2 and 3

51. The decimal value 0.5 in IEEE single precision floating point representation has fraction bits of

- (a) 000....000 and exponent value of 0
- (b) 000....000 and exponent value of -1
- (c) 100....000 and exponent value of 0
- (d) 100....000 and exponent value of -1

52. What does the following program print ?

```
void f(int*p, int*q)
{
    p = q;
    *p=2;
}
int i = 0, j = 1;
int main ( )
{
    f(&i, &j);
    printf("%d %d \n", i, j);
    getchar ( );
    return 0;
}
```

- (a) 2 2
- (b) 2 1
- (c) 0 1
- (d) 0 2

53. Consider the following set of processes with data thereof as given here :

Process	Arrival time	CPU Burst time
$P_1$	0 ms	12 ms
$P_2$	2 ms	4 ms
$P_3$	3 ms	6 ms
$P_4$	8 ms	5 ms

An operating system uses shortest remaining time first scheduling algorithm for pre-emptive scheduling of processes. The average waiting time of the processes is

- (a) 7.5 ms
- (b) 6.5 ms
- (c) 5.5 ms
- (d) 4.5 ms

54. The length of cable required for transmitting a data at the rate of 500 Mbps in an Ethernet LAN with frames of size 10,000 bits and for signal speed 2,00,000 km/s is

- (a) 2.5 km
- (b) 2.0 km
- (c) 1.5 km
- (d) 1.0 km

55. Consider the following statements :

1. System calls provide the interface between a process and the operating system
2. PERL implementations include direct system call access
3. System calls occur in different ways depending on the computer in use

Which of the above statements are correct ?

- (a) 1 and 2 only
- (b) 1 and 3 only
- (c) 2 and 3 only
- (d) 1, 2 and 3

56. What is the effective access time, if the average page-fault service time is 25 ms, memory access time is 100 ns and page-fault rate is  $P$  ?

- (a)  $100 + 24,999,900 \times P$  ns
- (b)  $100 + 25,000,000 \times P$  ns
- (c)  $100 + 25,000 \times P$  ns
- (d)  $25,000,000 + 100 P$  ns

57. Consider the function fun1 shown below:

```
int fun1 (int num)
{
    int count = 0;
    while (num)
    { count ++;
      num >>= 1;
    }
    return (count);
}
```

The value returned by fun1 (435) is

- (a) 10
- (b) 9
- (c) 8
- (d) 7

58. Consider the following statements in the relevant context :

1. The two types of currents that flow in semiconductor diodes and transistors are drift and diffusion currents
2. The junction region is called depletion region or space-charge region
3. When currents flow through the diode in forward bias, the depletion region current is mostly of 'diffusion' type

Which of the above statements are correct ?

- (a) 1, 2 and 3
- (b) 1 and 2 only
- (c) 1 and 3 only
- (d) 2 and 3 only

59. The bandwidth of a control system can be increased by using

- (a) Phase-lead network
- (b) Phase-lag network
- (c) Both Phase-lead network and Phase-lag network
- (d) Cascaded amplifier in the system

60. Applications of negative feedback to a certain amplifier reduced its gain from 200 to 100. If the gain with the same feedback is to be raised to 150, in the case of another such appliance, the gain of the amplifier without feedback must have been

- (a) 400
- (b) 450
- (c) 500
- (d) 600

61. Consider the following statements for a network graph, if  $B_f$  is its fundamental tie set matrix, and  $B_t$  and  $B_l$  are its sub-matrices corresponding to twigs and links, respectively :

1.  $B_t$  is a unit matrix
2.  $B_l$  is a rectangular matrix
3. Rank of  $B_f$  is  $(b - n - 1)$

where  $b$  is the number of branches and  $n$  is the number of nodes.

Which of the above statements are correct ?

- (a) 1 and 2 only
- (b) 1 and 3 only
- (c) 2 and 3 only
- (d) None of the above

62.

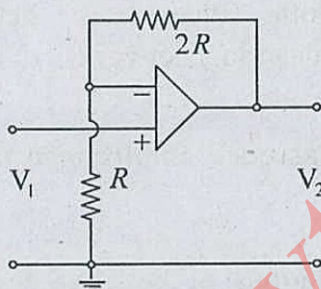

An ideal operational amplifier is connected as shown in figure. What is the output voltage  $V_2$  ?

- (a)  $3 V_1$
- (b)  $2 V_1$
- (c)  $1 V_1$
- (d)  $\frac{V_1}{3}$

63. The modulating index of an AM-signal is reduced from 0.8 to 0.5. The ratio of the total power in the new modulated signal to that of the original signal will nearly be

- (a) 0.39
- (b) 0.63
- (c) 0.85
- (d) 1.25

64. The Truth table for the function  $f(ABCD) = \sum m(0, 1, 3, 4, 8, 9)$  is

A	B	C	f
0	0	0	W
0	0	1	X
0	1	0	Y
0	1	1	0
1	0	0	Z
1	0	1	0
1	1	0	0
1	1	1	0

where  $W, X, Y, Z$  are given by ( $d$  is the complement of  $D$ )

- (a)  $D, d, 1, 1$
- (b)  $1, d, D, 1$
- (c)  $1, 1, D, d$
- (d)  $1, D, d, 1$

65. An 8-bit DAC uses a ladder network. The full-scale output voltage of the converter is +10V. The resolution expressed in percentage and in volts is, respectively

- (a) 0.25% and 30 mV
- (b) 0.39% and 30 mV
- (c) 0.25% and 39 mV
- (d) 0.39% and 39 mV

66. Consider the following statements :

1. Flash type ADCs are considered the fastest
2. In successive approximation type ADCs, conversion time depends upon the magnitude of the analog voltage
3. Counter-type ADCs work with fixed conversion time
4. Dual slope ADCs are considered the slowest

Which of the above statements are correct ?

- (a) 2 and 3 only
- (b) 2 and 4 only
- (c) 1 and 4 only
- (d) 1 and 3 only

67.

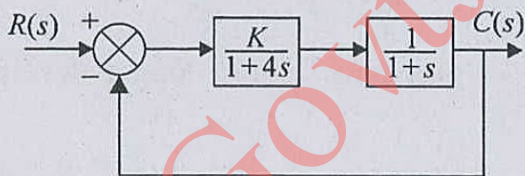

For the feedback control system shown, if the steady state error is 20% for the unit step input signal, then the value of  $K$  must be

- (a) 80
- (b) 40
- (c) 20
- (d) 4

68.

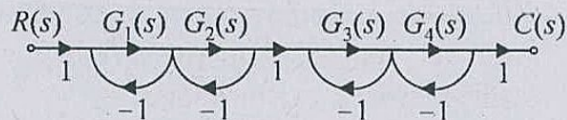

The closed-loop transfer function  $\frac{C(s)}{R(s)}$  of the system represented by the signal flow graph as shown in figure is

- (a)  $\frac{G_1 G_2 G_3 G_4}{(1 + G_1 + G_2)}$
- (b)  $\frac{G_1 G_2 G_3 G_4}{(1 + G_3 + G_4)}$
- (c)  $\frac{G_1 G_2 G_3 G_4}{(1 + G_1 + G_2)(1 + G_3 + G_4)}$
- (d)  $\frac{G_1 G_2 G_3 G_4}{(1 + G_1 G_2)(1 + G_3 G_4)}$

69.

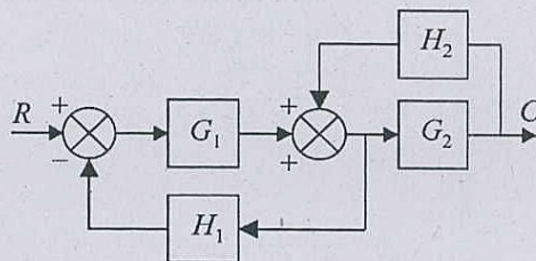

For the block diagram as shown in figure, the overall transfer function  $\frac{C}{R}$  is

- (a)  $\frac{G_1 G_2 H_1}{(1 - G_1 H_1 - G_2 H_2)}$
- (b)  $\frac{G_1 G_2}{(1 - G_1 H_1 + G_2 H_2)}$
- (c)  $\frac{G_1 G_2 H_2}{(1 + G_1 H_1 + G_2 H_2)}$
- (d)  $\frac{G_1 G_2}{(1 + G_1 H_1 - G_2 H_2)}$

70.

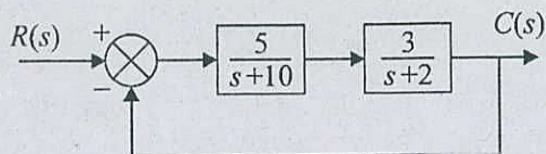

The block diagram shows a unity feedback closed-loop system. The steady-state error in the response to a unit step input is

- (a) 14%
- (b) 28%
- (c) 42%
- (d) 57%

71. The open-loop transfer function of a negative feedback is

$$G(s)H(s) = \frac{K}{s(s+5)(s+12)}$$

For ensuring system stability the gain  $K$  should be in the range

- (a)  $0 < K < 60$
- (b)  $0 < K < 600$
- (c)  $0 < K < 1020$
- (d)  $K > 1020$

72. The characteristic polynomial of a feedback control system is given by

$$R(s) = s^5 + 2s^4 + 2s^3 + 4s^2 + 11s + 10$$

For this system, the numbers of roots that lie in the left hand and right hand  $s$ -plane respectively, are

- (a) 5 and 0.
- (b) 4 and 1
- (c) 3 and 2
- (d) 2 and 3

73.

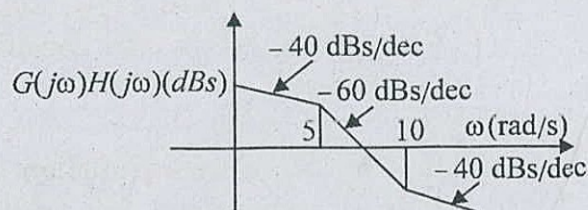

The open loop transfer function  $G(s)H(s)$  of a Bode's plot for feedback system as shown in figure is

(a)  $\frac{K(s+5)}{s^2(s+10)}$

(b)  $\frac{K(s+5)}{s(s+10)}$

(c)  $\frac{K(s+10)}{s^2(s+5)}$

(d)  $\frac{K(s+10)}{s(s+5)}$

74. A system with characteristic equation  $s^4 + 2s^3 + 11s^2 + 18s + 18 = 0$ , will have closed loop poles such that

- (a) All poles lie in the left half of the  $s$ -plane and no pole lies on imaginary axis
- (b) All poles lie in the right half of the  $s$ -plane
- (c) Two poles lie symmetrically on the imaginary axis of the  $s$ -plane
- (d) All four poles lie on the imaginary axis of the  $s$ -plane



75.

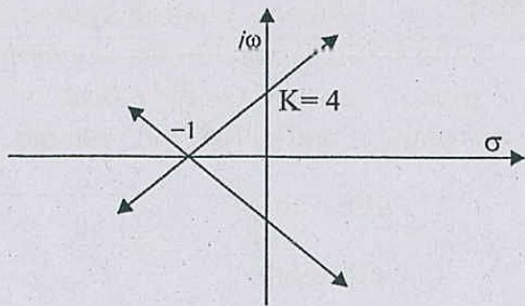

The open-loop transfer function  $G(s)H(s)$  of a root locus plot of a system as shown in figure is

- (a)  $\frac{4}{(s+1)^1}$
- (b)  $\frac{4}{(s+1)^2}$
- (c)  $\frac{4}{(s+1)^3}$
- (d)  $\frac{4}{(s+1)^4}$

76. The transfer function of a compensator is  $\frac{1+3sT}{1+sT}$ . The maximum possible phase shift is

- (a)  $30^\circ$
- (b)  $45^\circ$
- (c)  $60^\circ$
- (d)  $90^\circ$

77. The steady state response  $c(t)$  for an input  $r(t) = \sin 2t$  to a system transfer function  $\frac{1}{s+4}$  is

- (a)  $0.25 \sin 2t$
- (b)  $\sin(2t - 45^\circ)$
- (c)  $0.316 \sin(2t - 26.5^\circ)$
- (d)  $0.632 \cos 2t$

78.

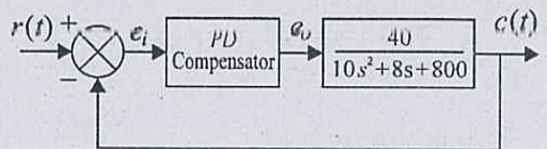

Compensation derived from the  $P-D$  network whose differential equation is governed by  $e_o = 20 \left( e_i + T \frac{de_i}{dt} \right)$  as shown in the figure is to be investigated. For what value of  $T$  will the closed-loop response be critically damped ?

- (a) 1.612
- (b) 0.806
- (c) 0.306
- (d) 0.161

79.

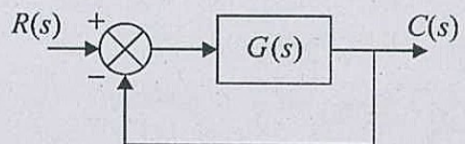

The unity feedback system as shown in the figure is characterized by  $G(s) = \frac{1}{(s+1)^2}$ . The output time response will have a damping factor  $\zeta$ , and natural frequency  $\omega_n$ , respectively, as

- (a) 0.707 and 1
- (b) 0.866 and  $\sqrt{2}$
- (c) 0.707 and  $\sqrt{2}$
- (d) 0.866 and 1

80. For a state model

$\dot{X} = AX$ , where  $A = \begin{bmatrix} 1 & 0 \\ 1 & 1 \end{bmatrix}$ , the state transition matrix is

(a)  $\begin{bmatrix} te^{-t} & 0 \\ e^t & e^t \end{bmatrix}$

(b)  $\begin{bmatrix} 0 & t \\ e^t & te^t \end{bmatrix}$

(c)  $\begin{bmatrix} e^t & 0 \\ te^t & e^t \end{bmatrix}$

(d)  $\begin{bmatrix} t & 0 \\ t^2 & e^t \end{bmatrix}$

81.

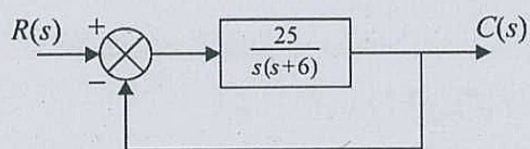

A unit step input to a unity feedback system is shown in the figure, the time for peak overshoot is, nearly

(a) 0.35 s

(b) 0.58 s

(c) 0.79 s

(d) 0.96 s

82. The transient response of second order under damped system starting from rest is given by  $c(t) = A e^{-6t} \sin(8t + \theta)$ ,  $t \geq 0$ . The natural frequency of the system is

(a) 8

(b) 9

(c) 10

(d) 100

83. For a feedback control system all the roots of the characteristic equation can be placed at the desired location in the s-plane if and only if the system is

1. Observable

2. Controllable

Which of the above statements are correct ?

(a) 1 only

(b) 2 only

(c) Both 1 and 2

(d) Neither 1 nor 2

84. A second order system with a zero at  $-2$  has its poles located at  $-3 + j4$  and  $-3 - j4$  in the s-plane. The undamped natural frequency and the damping factor of the system respectively are

(a) 3 rad/s and 0.80

(b) 5 rad/s and 0.80

(c) 3 rad/s and 0.60

(d) 5 rad/s and 0.60

85.

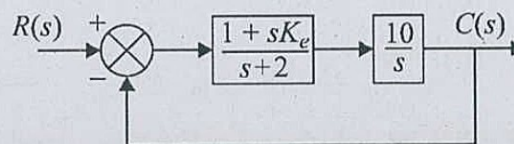

What is the error-rate factor  $K_e$  to yield a damping factor of 0.5 for the system shown in the block diagram ?

(a) 0.116

(b) 0.232

(c) 0.284

(d) 0.332

86. An ideal transformer is having 150 turns primary and 750 turns secondary. The primary coil is connected to a 240V, 50 Hz source. The secondary winding supplies a load of 4A at lagging power factor of 0.8. What is the power supplied by the transformer to the load ?

- (a) 4200 W
- (b) 3840 W
- (c) 2100 W
- (d) 1920 W

87. In an induction motor for a fixed speed at constant frequency

- (a) Both line current and torque are proportional to voltage
- (b) Both line current and torque are proportional to the square of voltage
- (c) Line current is proportional to voltage and torque is proportional to the square of voltage
- (d) Line current is constant and torque is proportional to voltage

88.

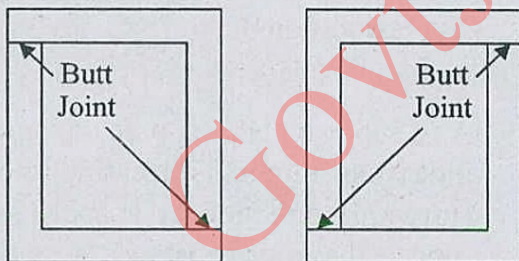

In a core-type single-phase transformer the steel-core is assembled by staggering butt-joints in adjacent layers of laminations vide figures. The purpose served is said to be

- 1. Avoiding continuous air-gap
- 2. Preventing loss of mechanical strength
- 3. Reducing eddy-current loss

Which of the above statements are true ?

- (a) 1 and 2 only
- (b) 1 and 3 only
- (c) 2 and 3 only
- (d) 1, 2 and 3

89. Which of the following would refer to an ideal transformer ?

- 1. Winding-resistances are negligible
- 2. Leakage-fluxes are included
- 3. Core-losses are negligible
- 4. Magnetization characteristic is linear

- (a) 1, 2 and 3 only
- (b) 1, 3 and 4 only
- (c) 1, 2 and 4 only
- (d) 2, 3 and 4 only

90. A 24-slot, 2-pole, lap-wound dc machine has 18 turns per coil. The average flux density per pole is 1 Tesla. The effective length of the machine is 20 cm and the radius of the armature is 10 cm. The magnetic poles cover 80% of the armature periphery. For armature angular velocity ( $\omega_m$ ) of 183.2 rad/sec, the induced emf in the armature winding is nearly

- (a) 585 V
- (b) 1050 V
- (c) 1260 V
- (d) 1465 V

91. A 220 V dc compound generator connected in long-shunt mode has the following parameters:  $R_a = 0.1 \Omega$ ,  $R_{sh} = 80 \Omega$ ,  $R_{series} = 0.05 \Omega$ . For a load of  $150 \text{ A}$  at rated terminal voltage, the induced emf of the generator should nearly be

- (a) 233 V
- (b) 243 V
- (c) 251 V
- (d) 262 V

92. The Laplace transform of  $f(t) = t^n e^{-\alpha t} u(t)$  is

- (a)  $\frac{(n+1)!}{(s+\alpha)^{n+1}}$
- (b)  $\frac{n!}{(s+\alpha)^n}$
- (c)  $\frac{(n-1)!}{(s+\alpha)^{n+1}}$
- (d)  $\frac{n!}{(s+\alpha)^{n+1}}$

93. A dc shunt motor has the following characteristics,  $R_a = 0.5 \Omega$ ,  $R_f = 200 \Omega$ , base speed = 1000 rpm, rated voltage = 250 V. On no load it draws a current = 5 A. At what speed will this run while delivering a torque of 150 N.m?

- (a) 881 rpm
- (b) 920 rpm
- (c) 950 rpm
- (d) 990 rpm

94.

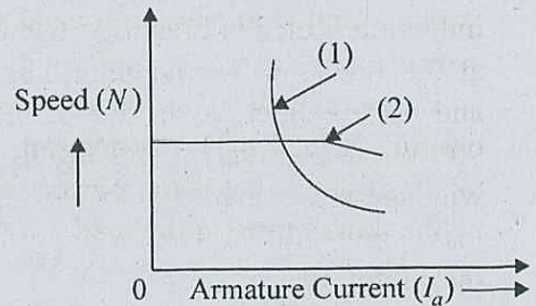

The figure shows plots of speed (N) Vs. armature current ( $I_a$ ) of a dc motor for two different operating conditions. Which one of the following features is relevant?

- (a) (1) represents stronger shunt field, and (2) represents stronger series field of a compound motor
- (b) (1) represents stronger series field, and (2) represents stronger shunt field of a compound motor
- (c) (1) represents only shunt excitation, and (2) represents only series excitation
- (d) (1) represents only series excitation, and (2) represents only shunt excitation

95. A 230 V, 50 Hz, 4-pole, single-phase induction motor is rotating clockwise (forward) direction at a speed of 1425 rpm. If the rotor resistance at standstill is  $7.8 \Omega$ , then the effective rotor resistance in the backward branch of the equivalent circuit will be

- (a)  $2.0 \Omega$
- (b)  $4.0 \Omega$
- (c)  $78 \Omega$
- (d)  $156 \Omega$

96. A 400 V, 50 Hz, 30 hp, three phase induction motor is drawing 50 A current at 0.8 power factor lagging. The stator and rotor copper losses are 1.5 kW and 900 W respectively. The friction and windage losses are 1050 W and the core losses are 1200 W. The air gap power of the motor will be, nearly
- 15 kW
  - 20 kW
  - 25 kW
  - 30 kW
97. When the value of slip of an induction motor approaches zero, the effective resistance
- is very low and the motor is under no-load
  - of the rotor circuit is very high and the motor is under no-load
  - is zero
  - of the rotor circuit is infinity and the motor is equivalent to short-circuited two-winding transformer
98. A 4-pole, 50 Hz, 3-phase induction motor with a rotor resistance of  $0.25 \Omega$  develops a maximum torque of 25 N.m at 1400 rpm. The rotor reactance  $x_2$  and slip at maximum torque  $s_{\max, T}$  respectively would be
- 2.0 and  $\frac{1}{15}$
  - 3.75 and  $\frac{1}{12}$
  - 2.0 and  $\frac{1}{12}$
  - 3.75 and  $\frac{1}{15}$
99. A 3-phase, 37 kW induction motor has an efficiency of 90% when delivering full load. At this load the stator copper losses and rotor copper losses are equal and are equal to stator iron losses. The mechanical losses are one-third of no-load losses. Then the motor runs at a slip of
- 0.01
  - 0.02
  - 0.03
  - 0.04
100. The rotor of a 4-pole ac generator is wound with a 200 turns coil. If the flux per pole is 5 m Wb and the rotor runs at a speed of 1500 rpm, the rms value of the induced voltage for this ac generator is nearly
- 140 V
  - 157 V
  - 164 V
  - 200 V
101. A 3-MVA, 6-pole, 50 Hz, 3-phase synchronous generator is connected to an infinite bus of 3300 V; and it is run at 1000 rpm. The synchronous reactance of the machine is  $0.915 \Omega$  per phase. The synchronizing torque for  $1^\circ$  mechanical displacement of the rotor is
- 7500 N.m
  - 7000 N.m
  - 6000 N.m
  - 4500 N.m

102. The second-harmonic component of the power  $P$  versus load angle  $\delta$  characteristic of a synchronous machine, operating at a terminal voltage  $V_t$  and having the  $d$ - and  $q$ -axis reactance per phase of  $X_d$  and  $X_q$ , respectively, is

(a)  $\frac{V_t^2}{2} \cdot \frac{X_d X_q}{X_d + X_q} \sin 2\delta$

(b)  $\frac{V_t^2}{2} \cdot \left( \frac{1}{X_q} - \frac{1}{X_d} \right) \sin 2\delta$

(c)  $\frac{V_t^2}{2} \cdot \frac{X_d X_q}{X_d + X_q} \cos 2\delta$

(d)  $\frac{V_t^2}{2} \cdot \left( \frac{1}{X_q} - \frac{1}{X_d} \right) \cos 2\delta$

103. The term Synchronous condenser refers to

- (a) A synchronous motor with a capacitor connected across the stator terminals to improve the power factor
- (b) A synchronous motor operating at full-load with leading power factor
- (c) An over-excited synchronous motor partially supplying mechanical load and also improving the power factor of the system to which it is connected
- (d) An over-excited synchronous motor operating at no-load with leading power factor used in large power stations for improvement of power factor

104. Which of the following operating aspects necessitate the computation of Regulation of an alternator ?

- 1. When load is thrown off
- 2. For designing of an automatic voltage-control equipment
- 3. For determination of steady-state and transient stability
- 4. For parallel operation of alternators

(a) 1, 2 and 3 only

(b) 1, 2 and 4 only

(c) 1, 3 and 4 only

(d) 1, 2, 3 and 4

105. A 2-phase ac servomotor has a tendency to run as a single-phase induction motor, if the voltage across the control winding becomes zero. To prevent this

- (a) Rotor having high mass and moment of inertia is to be used
- (b) Drag-cup type of light rotor and high resistance is to be used
- (c) A low resistance rotor is to be used
- (d) The number of turns in the control winding is to be kept lesser than in the main reference winding

106. A single-stack, 8-phase (stator), multiple-step motor has 6-rotor teeth. The poles are excited one at a time. If excitation frequency is 120 Hz, the speed of the motor is

(a) 3 rps

(b) 5 rps

(c) 10 rps

(d) 15 rps

107. An extra high voltage transmission line of length 300 km can be approximated by a lossless line having propagation constant  $\beta = 0.00127$  rad/km. The percentage ratio of line length to wavelength will nearly be
- (a) 24%  
 (b) 19%  
 (c) 12%  
 (d) 6%
108. A lossy capacitor  $C_x$ , rated for operation of 5 kV, 50 Hz is represented by an equivalent circuit with an ideal capacitor  $C_p$  in parallel with a resistor  $R_p$ .  $C_p$  is  $0.102 \mu\text{F}$ ; and  $R_p = 1.25 \text{ M}\Omega$ . The power loss, and  $\tan \delta$ , of this lossy capacitor when operating at the rated voltage are, respectively
- (a) 20 W and 0.04  
 (b) 10 W and 0.04  
 (c) 20 W and 0.025  
 (d) 10 W and 0.025
109. The time interval needed for a surge to travel to the end of a 600 km long overhead transmission line is
- (a) 6 s  
 (b) 2 s  
 (c) 20 ms  
 (d) 2 ms
110. At what power factor will a lossless line with a reactance of  $0.6 \text{ pu}$  exhibit zero regulation given that the sending-end voltage is  $1.0 \text{ pu}$  ?
- (a) 0.800 lag  
 (b) 0.800 lead  
 (c) 0.954 lead  
 (d) Unity p.f.
111. An 11 kV, 3-phase transmission line has resistance of  $1.5 \Omega$  and reactance of  $4 \Omega$  per phase. The efficiency of the line when supplying the load of 4 MW at 0.8 lagging power factor is nearly
- (a) 99%  
 (b) 95%  
 (c) 92%  
 (d) 90%
112. The dielectric loss in the insulation of a lossy underground cable, due to leakage current is (using standard notations)
- (a)  $\omega CV^2 \cos \delta$   
 (b)  $\omega CV \tan \delta$   
 (c)  $\omega CV^2 \tan \delta$   
 (d)  $\omega CV \sin \delta$

113. A 3-phase, 100 MVA, 11 kV generator has the following p.u. constants. The generator neutral is solidly grounded.  $X_1 = X_2 = 3X_0 = 0.15\Omega$ . The ratio of the fault current due to three-phase dead-short-circuit to that due to L-G fault would be nearly

- (a) 0.33
- (b) 0.56
- (c) 0.78
- (d) 1.0

114.

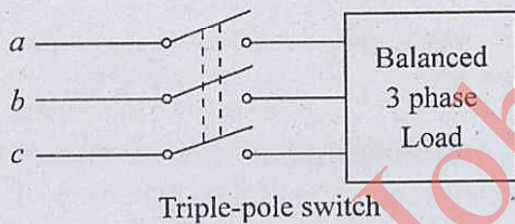

A balanced 3-phase load is supplied from a 3-phase supply. The contact in line  $c$  of the triple-pole switch contactor fails to connect when switched on. If the line-currents in lines  $a$  and  $b$  record 25A each, then the positive-sequence component of the current is

- (a)  $14.4 \angle +30^\circ$  A
- (b)  $25.0 \angle -30^\circ$  A
- (c)  $14.4 \angle -30^\circ$  A
- (d)  $25.0 \angle +30^\circ$  A

115. In a circuit-breaker, the arc is produced due to

1. Thermal emission
2. High temperature of air
3. Field emission

Which of the above statements are correct ?

- (a) 1, 2 and 3
- (b) 2 and 3 only
- (c) 1 and 2 only
- (d) 1 and 3 only

116. The line reactances of a power network are as follows :

Line No.	From Bus	To Bus	Reactance
1	0	1	0.2 p.u.
2	1	2	0.4 p.u.

The bus impedance matrix with '0' as ref-bus is

- (a)  $\begin{bmatrix} 0.2 & 0.4 \\ 0.4 & 0.6 \end{bmatrix}$
- (b)  $\begin{bmatrix} 0.4 & 0.2 \\ 0.2 & 0.6 \end{bmatrix}$
- (c)  $\begin{bmatrix} 0.2 & 0.2 \\ 0.2 & 0.6 \end{bmatrix}$
- (d)  $\begin{bmatrix} 0.6 & 0.2 \\ 0.2 & 0.4 \end{bmatrix}$



117. An alternator is
- A polyphase synchronous machine operated with DC exciter
  - A polyphase synchronous machine operated with AC exciter
  - A three-phase induction machine with prime mover
  - Any AC generator
118. The stability of a system, when subjected to a disturbance, is assessable by which of the following methods ?
- Swing curve
  - Equal-area criterion
  - Power-angle diagram
  - Power-circle diagram
- 1, 2 and 4 only
  - 1, 3 and 4 only
  - 2, 3 and 4 only
  - 1, 2 and 3 only
119. Power transmission capacity of a high voltage line can be increased by
- Increasing the resistance of the line
  - Increasing the inductive reactance of the line
  - Reducing the effective series reactance of the line
  - Reducing the shunt admittance of the line
120. A 40 MVA, 11kV, 3-phase, 50Hz, 4-pole turbo-alternator has an inertia constant of 15 sec. An input of 20 MW developed 15 MW of output power (Neglecting losses). Then the acceleration is
- $60^\circ/s^2$
  - $65^\circ/s^2$
  - $70^\circ/s^2$
  - $75^\circ/s^2$
121. In a Progressive Simplex Lap Winding for a 4-pole, 14-slot, 2 coil-sides per slot d.c. armature, the back pitch  $y_b$  and front pitch  $y_f$  will be respectively
- 7 and 5
  - 5 and 5
  - 7 and 7
  - 5 and 7
122. The starting current in an induction motor is 5 times the full-load current while the full load slip is 4%. The ratio of starting torque to full-load torque is
- 0.6
  - 0.8
  - 1.0
  - 1.2
123. When bundle of conductors are used in place of single conductors the effective inductance and capacitance will, respectively
- Increase and decrease
  - Decrease and increase
  - Decrease and remain unaffected
  - Increase and remain unaffected

124. A buck regulator has an input voltage of 12V and the required output voltage is 5V. What is the duty cycle of the regulator ?

- (a)  $\frac{5}{12}$
- (b)  $\frac{12}{5}$
- (c)  $\frac{5}{2}$
- (d) 6

**Directions :**

Each of the next Twenty Six (26) items consists of two statements, one labelled as 'Statement (I)' and the other as 'Statement (II)'. Examine these two statements carefully and select the answers to these items using the codes given below :

**Codes :**

- (a) Both Statement (I) and Statement (II) are individually true; and Statement (II) is the correct explanation of Statement (I)
- (b) Both Statement (I) and Statement (II) are individually true; but Statement (II) is NOT the correct explanation of Statement (I)
- (c) Statement (I) is true; but Statement (II) is false
- (d) Statement (I) is false; but Statement (II) is true

125. Statement (I) : An electrolytic capacitor consists of two electrodes immersed in an electrolyte with a chemical film on one of the electrodes acting as the dielectric.

Statement(II) : The electrolytic capacitor may be operated with any one of the electrodes as anode positive with respect to the other.

126. Statement (I) : Two ideal current sources with currents  $I_1$  and  $I_2$  cannot be connected in series.

Statement(II) : Superposition Theorem cannot be applied to current sources when one terminal of each of these sources is connected to a common node.

127. Statement (I) : Both Coupling capacitance and Emitter bypass capacitance affect the low frequency response of an R-C-coupled amplifier.

Statement (II) : Both Stray capacitances and Emitter-to-base diffusion capacitance have a profound effect on the low frequency response of an R-C-coupled amplifier.

128. Statement (I) : A 'bedding' is provided over to the metallic sheath in an underground cable.

Statement(II) : The bedding protects the metallic sheath against corrosion.

129. Statement (I) : Zero-sequence currents are, by definition, in phase with each other in the three windings of any three-phase apparatus.

Statement(II) : They may be caused by magnetic saturation in the transformers.

130. Statement (I) : 'High resistance' method is used for arc extinction in DC circuit breakers.

Statement(II) : Very little energy is dissipated in the arc in high resistance method of arc extinction.

131. Statement (I) : A radial main system, circuit experiences a low voltage at the far end under heavy load conditions.

Statement(II) : The voltage at the far end under heavy loading can be corrected by connecting a shunt capacitor compensator there.

132. Statement (I) : In an HVDC system, the steady-state power transfer from a generator to the infinite bus is dependent on the power angle and the line impedance intervening between them.

Statement(II) : In an HVDC system, the power transfer between the two stations connected by a dc link is much larger than that in a corresponding EHV ac system.

133. Statement (I) : Conventional diode rectifier circuits have low frequency harmonics.

Statement(II) : Passive techniques used to reduce the current THD in conventional rectifiers require large transformers and/or reactors.

134. Statement (I) : Resonant inverters are used as electronic ballasts for gas discharge lamps, induction heating, etc.

Statement(II) : A DC to high frequency AC resonant inverter may be obtained by applying the square wave voltage obtained from a DC source and switch network operating at frequency  $f_s$  to a tuned tank circuit designed for frequency  $f_o$ , so as to obtain variable magnitudes of  $v(t)$  and  $i(t)$  by matching  $f_s$  with  $f_o$ .

135. Statement (I) : In linear commutation, the magnitude of the current in the coils under each pole in a DC generator on a given load remains constant.

Statement(II) : The magnitude of the emfs induced in the coils under each pole of a DC generator on load remains constant.

136. Statement (I) : A very efficient method of speed control of an induction motor is to vary both  $V$  and  $f$  in such a way that  $\frac{V}{f}$  ratio remains constant.

Statement(II) : Keeping  $\frac{V}{f}$  constant allows the magnetic flux to remain constant and a reduced  $V$  reduces the inrush of starting current.

137. Statement (I) : Windings of most power transformers are immersed in a tank of oil.

Statement(II) : Convection currents in the insulating oil help carry the heat away from the windings and the core.

138. Statement (I) : A large gate pulse is required to turn on a GTO thyristor.

Statement(II) : This thyristor does not need a commutation circuit.

139. Statement (I) : The decimal-to-BCD encoder digital logic circuit chip IC 74147, is a priority encoder.

Statement(II) : In this circuit, priority is given to the lowest-order input.

140. Statement (I) : Analog to digital conversion is essentially a sampling process.

Statement(II) : A hold element is digital to analog converter.

141. Statement (I) : High-level programming languages preferred by the scientific community as they are user friendly.

Statement(II) : High level programming languages provide ways of detailing instruction for problem-solving that are translated into low-level language via compilers and interpreters before being executed by the computer.

142. Statement (I) : The conductivity of an intrinsic semi-conductor increases exponentially with temperature.

Statement(II) : As the temperature rises, more and more covalent bonds are broken resulting in more electron hole pairs.

143. Statement (I) : Light is capable of transferring electrons to the free-state inside a material, thus increasing the electrical conductivity of the material.

Statement(II) : The increased electrical conductivity produced by light is called photo-conductivity.

144. Statement (I) : A general purpose dynamometer type wattmeter does not read accurately at low power factors.

Statement(II) : The presence of self-inductance of the pressure coil introduces an error.

145. Statement (I) : A dynamometer type wattmeter has a linear scale while a dynamometer type voltmeter has a non-linear scale.

Statement(II) : Deflecting torque developed in a dynamometer type wattmeter is proportional to the power and that developed in a dynamometer type ammeter is proportional to the square of the current.

146. Statement (I) : The rotating disc in an energy meter is made of a magnetic material.

Statement(II) : Braking takes place due to eddy current generated by the braking magnet.

147. Statement (I) : When a solid surface is bombarded by electrons of appreciable energy, secondary emission occurs from the surface.

Statement(II) : The major application of the secondary emission is in voltage amplification.

148. Statement (I) : Electromagnetic flow meter is preferred for flow velocity measurement of slurries in pipes as long as the slurry has adequate electrical conductivity.

Statement(II) : Electromagnetic flow meter does not insert any instrument parts into the body of the fluid flow to cause obstruction as in most of other flowmeters.

149. Statement (I) : Direct access method is based on a disk model of a file.

Statement(II) : Disks allow random access to any file block.

150. Statement (I) : Variables that are defined inside subprograms are local variables.

Statement(II) : Their scope is in the body of the subprogram in which they are defined.

**SPACE FOR ROUGH WORK**

GovtJobsAlert.In

**SPACE FOR ROUGH WORK**

GovtJobsAlert.In

**SPACE FOR ROUGH WORK**

GovtJobsAlert.In